

UPPER FLOOR PLAN S = 1/100

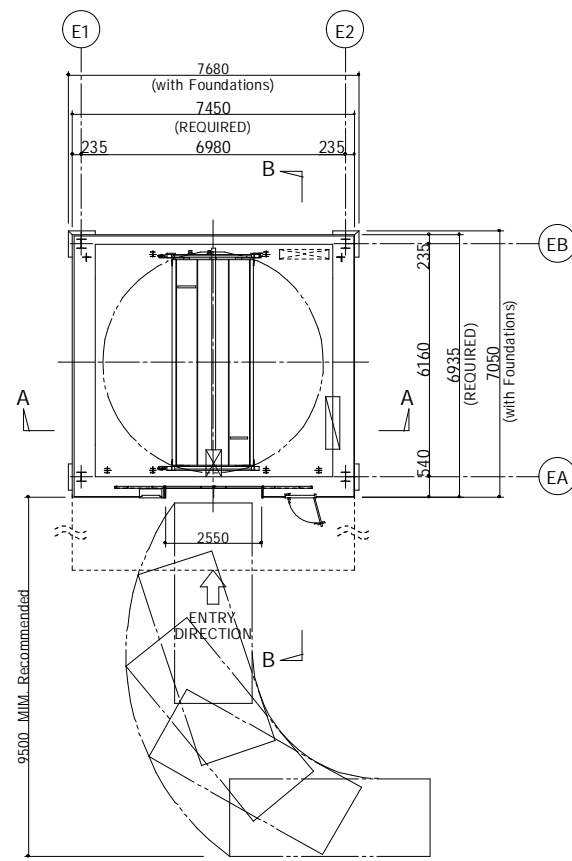

ENTRANCE-FLOOR (EL) LAYOUT PLAN S = 1/100

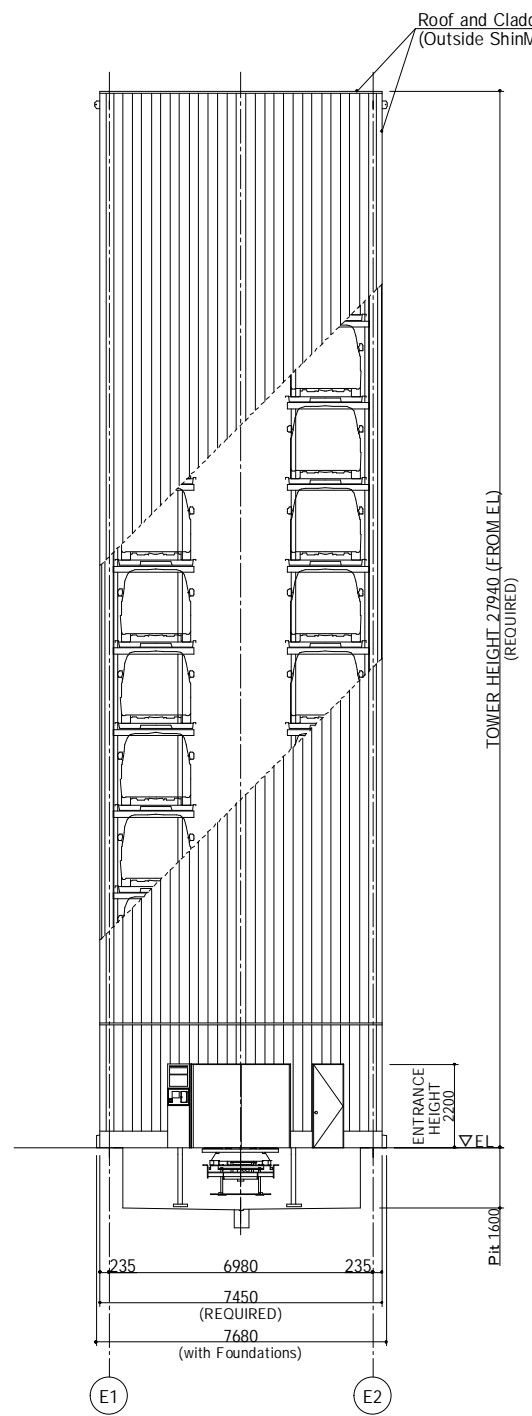

A-A SECTION S = 1/100

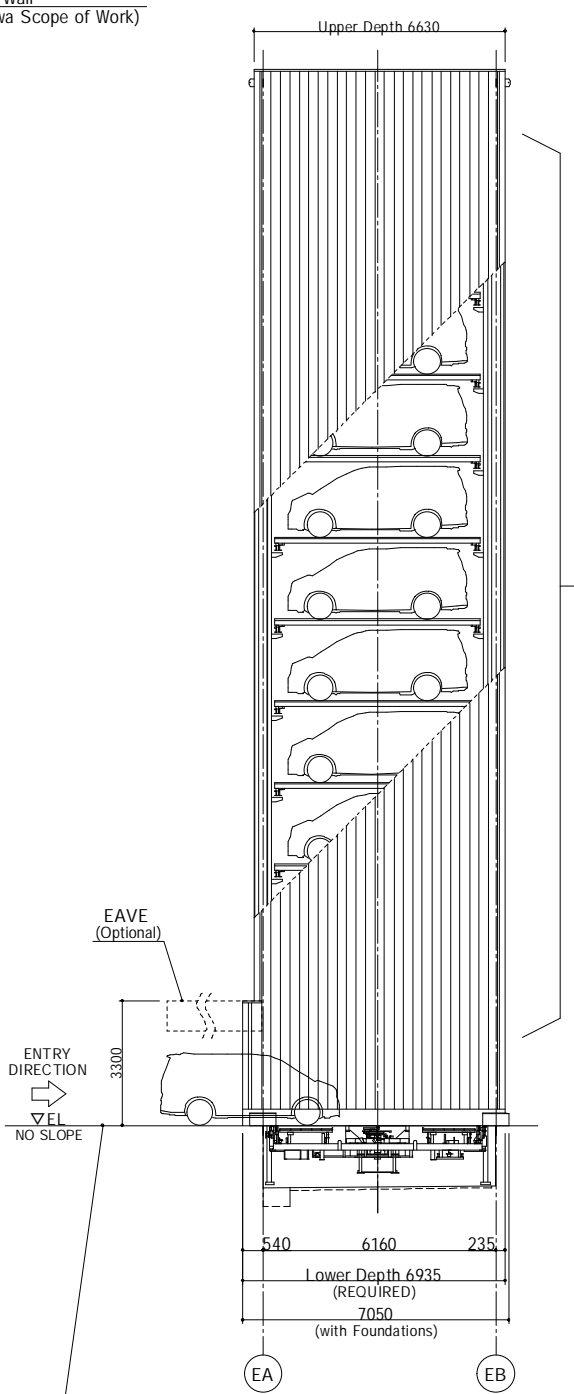

B-B SECTION S = 1/100

SUV
H=2000
22CARS/BLOCK
FLAT PALLET

PRODUCT SPECIFICATION	
NAME	ELEPARK (Elevator Type Parking System)
MODEL	ET2AXH-22T2-EFP(H22)
CAPACITY	TOTAL: 22 CARS /BLOCK SUV 22 CARS /BLOCK
CAR DIMENSION	
MAX LENGTH	5300mm
MAX WIDTH	2050mm*
MAX HEIGHT	2000mm
MAX WEIGHT	2400kg
TIRE OUTER DIMENSION	2050mm
MIN. GROUND CLEARANCE	90mm
*Side-view mirrors must be folded	
Side-view Mirrors folded	MAX. WIDTH
TIRE OUTER DIMENSION	MAX. LENGTH
MIN. GROUND CLEARANCE	MAX. HEIGHT
Antennas	Cargo on top
Protruding Front mirrors	Protruding Rear mirrors
Protruding Accessories	Protruding Mufflers or hooks
<Caution>	
1. Cars with protruding parts or accessories cannot be stored.	
2. Be sure to fold the side-view mirrors when parking.	
DIRECTION	FORWARD ENTRY, FORWARD EXIT
OPERATION METHOD	SMART CARD, TOUCHSCREEN
POWER SUPPLY CAPACITY	32 kVA /BLOCK (TOTAL HEIGHT ≤ 46.05m)
POWER	
ASCENT AND DESCENT	AC3 φ 200V 18.5 kW /BLOCK
SLIDE AND ROTATE	1.1 kW /BLOCK
LIFT	3.7 kW /BLOCK
CONTROL VECTOR INVERTER	
SPEED	
ASCENT AND DESCENT	60-120m/min (AUTOMATIC VARIABLE SPEED)
SLIDE	40m/min
ROTATION	5.6 rpm
LIGHTING	
GROUND FLOOR: LED TUBE x 4/BLOCK UPPER FLOOR: MAINTENANCE LIGHTS	
AUTO DOOR	
SYSTEM	2 PANELS CENTER-OPEN SLIDING DOOR/BLOCK
DIMENSION	WIDTH: 2550mm x HEIGHT: 2200mm
MATERIAL	STEEL (COATING FINISHING)

<NOTE>
1) Specifications are based on Japan Standard or ShinMaywa Standard.
2) This is the concept drawing for reference use only.
Please contact us for further information and optional specification (eave length etc.)
3) A transformer must be installed for use with local power grid.
(Outside ShinMaywa scope of work)

ShinMaywa
REFERENCE
DRAWING
Recommended Use:
SUPERCAR
CAD_ET2AXH-22T2-EFP(H22)