

UPPER FLOOR PLAN S = 1/100

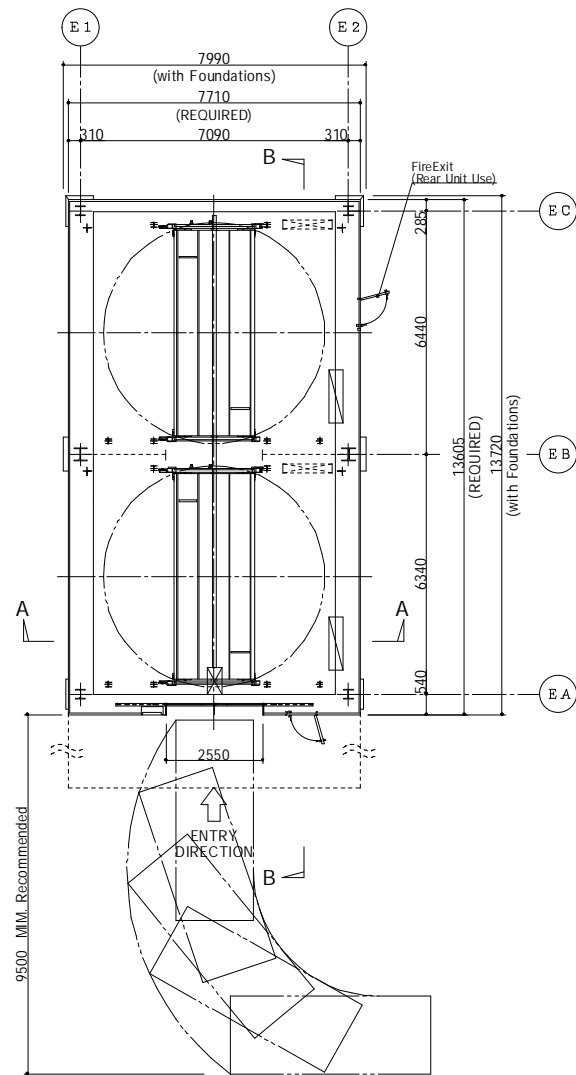

ENTRANCE-FLOOR (EL) LAYOUT PLAN S = 1/100

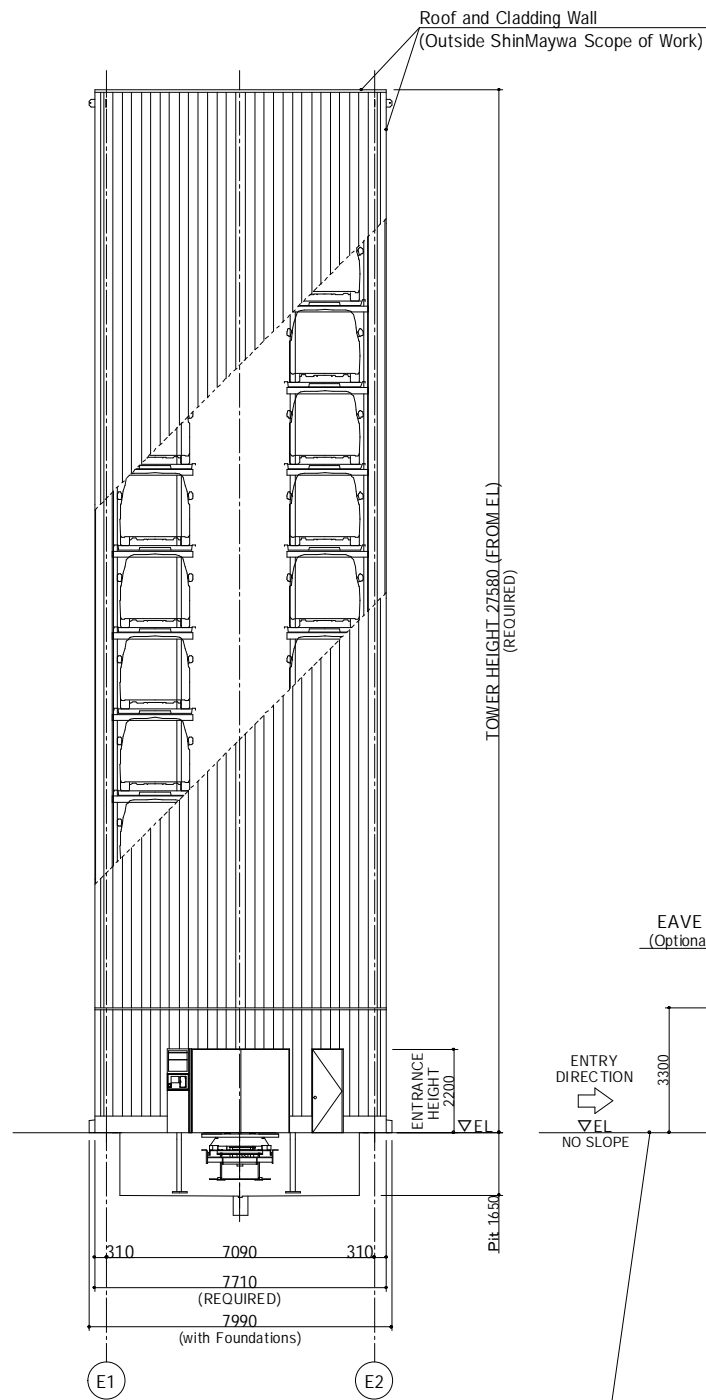

A-A SECTION S = 1/100

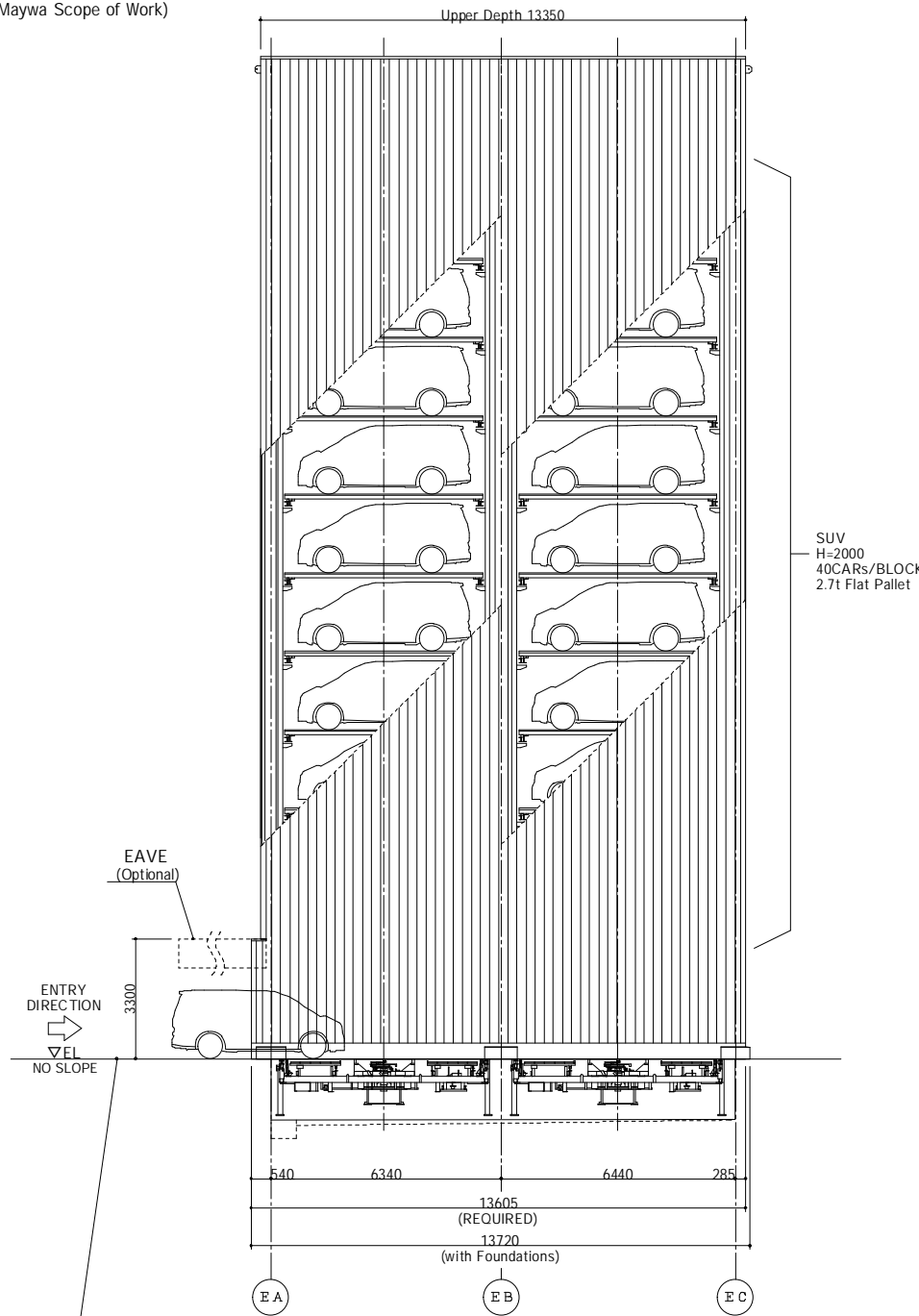

B-B SECTION S = 1/100

PRODUCT SPECIFICATION	
NAME	ELEPARK (Elevator Type Parking System)
MODEL	EW2AXH-20T2*AXH-20T2-EHP(H40)
CAPACITY	TOTAL: 40 CARS /BLOCK SUV 40 CARS /BLOCK
CAR DIMENSION	
MAX LENGTH	5300mm
MAX. WIDTH	2050mm*
MAX. HEIGHT	2000mm
MAX. WEIGHT	2700kg
TIRE OUTER DIMENSION	2050mm
MIN. GROUND CLEARANCE	90mm
*Side-view mirrors must be folded	
Side-view Mirrors folded	MAX. WIDTH
TIRE OUTER DIMENSION	MAX. LENGTH
MIN. GROUND CLEARANCE	MAX. HEIGHT
Antennas	Cargo on top
Protruding Front mirrors	Protruding Rear mirrors
Protruding Accessories	Protruding Mufflers or hooks
<p><Caution> 1. Cars with protruding parts or accessories cannot be stored. 2. Be sure to fold the side-view mirrors when parking.</p>	
DIRECTION	FORWARD ENTRY, FORWARD EXIT
OPERATION METHOD	SMART CARD, TOUCHSCREEN
POWER SUPPLY CAPACITY	128 kVA /BLOCK (TOTAL HEIGHT ≤ 46.05m)
POWER	
ASCENT AND DESCENT	AC3 φ 200V 37 kW x 2/BLOCK
SLIDE AND ROTATE	1.1 kW x 2/BLOCK
LIFT	3.7 kW x 2/BLOCK
CONTROL	VECTOR INVERTER
SPEED	
ASCENT AND DESCENT	120m/min
SLIDE	40m/min
ROTATION	5.6 rpm
LIGHTING	GROUND FLOOR: LED TUBE x 8/BLOCK UPPER FLOOR: MAINTENANCE LIGHTS
AUTO DOOR	
SYSTEM	2 PANELS CENTER-OPEN SLIDING DOOR/BLOCK
DIMENSION	WIDTH: 2550mm x HEIGHT: 2200mm
MATERIAL	STEEL (COATING FINISHING)

<NOTE>
 1) Specifications are based on Japan Standard or ShinMaywa Standard.
 2) This is the concept drawing for reference use only.
 Please contact us for further information and optional specification (eave length etc.)
 3) A transformer must be installed for use with local power grid.
 (Outside ShinMaywa scope of work)

ShinMaywa
REFERENCE DRAWING
 Recommended Use:
 HEAVY SUV, SUPERCAR
 CAD_EW2AXH-20T2AXH-20T2-EHP(H40)