

DUMP TRUCK DR SERIES

Employing in-house hydraulic components of our own make such as "TENTSUKI" Tipping Gear and Dump Bodies.



▲U-section drop tailgate type (for sand, soil and gravel)



▲"TENTSUKI" Tipping Gear

"TENTSUKI" Tipping Mechanism
Unique three-point support structure ensures higher anti-torsion strength while tipping. (4 tonner and larger models)

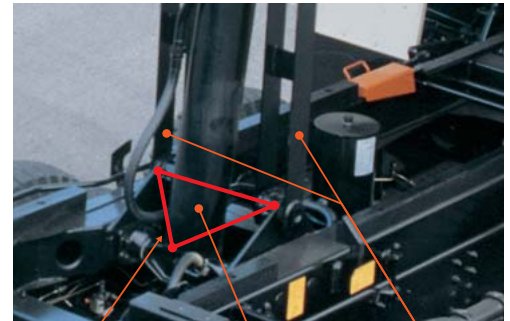

Three-point support

Hoist cylinder

Tension link



▲Square section drop side and tail-gate type (for sand and gravel)



▲Body-less type (ready for mounting a body)



▲ Tailgate opens automatically as the body is raised for dumping.

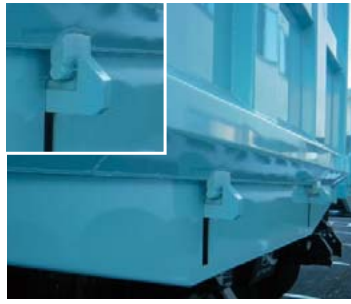

▲ Tailgate hook for deep bodies (Model DR11)

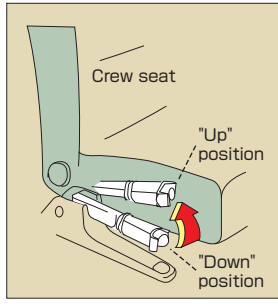

▲ Dump lever
Dumping operation can be done in the cab.

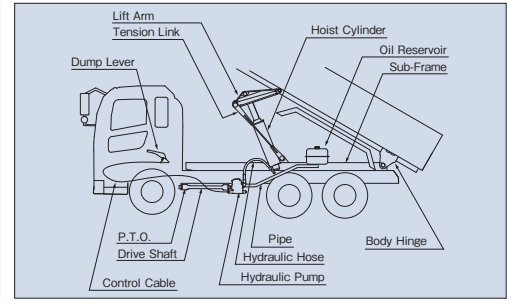

▲ Power stream: Truck engine → Transmission PTO → Oil pump → Dump cylinder

Specifications (for sands and gravels)

Model	Body inside dimension (mm)			Standard body volume	Tipping performance			GVW
	Length	Width	Height		Tipping angle	Lifting time	Lowering time	
DR2	2,800~3,000	1,600~1,900	250~350	1.5~2.0m ³	52~58°	20sec	20sec	3,300~5,200kg
DR4	3,000~3,400	1,900~2,060	340~600	2.3~3.6m ³	52~60°			8,000~10,400kg
DR7	3,500~3,600	2,000~2,070	500~650	4.0~4.5m ³	53~57°			11,000~11,900kg
DR8	3,800~4,000	2,200~2,300	550~700	5.0~6.0m ³	50~56°			12,000~18,000kg
DR(S) 11	4,800~5,300	2,200~2,300	900~950	7.0~10.0m ³	50~53°			19,000~29,000kg
DR(S) 11*	4,800~5,500	2,200~2,300	850~1,500	11.0~17.0m ³	50~53°			30,000~39,500kg

* Heavy weight class.

* The above mentioned figures are approximate.

Optional bodies



▲ U-section body with high hinge



▲ Refuse dump body



▲ Scoop end type (for rock and heavy material)



▲ Refuse dump body with canopy



▲ Rock dump body



▲ Three Way Dump Body

* Optional equipment are included in these photographs.

* Specifications and dimensions are subject to change without notice.

* Kit supply is available.

ShinMaywa Industries, Ltd.

International Sales Dept.
Special Purpose Truck Div.

3-2-43, Shitte, Tsurumi-ku, Yokohama, 230-0003, Japan

Telephone : +81-45-575-5163

Facsimile : +81-45-575-9837

e-mail : overseas@shinmaywa.co.jp

<http://www.shinmaywa.co.jp>